

1200 Series Stepper Amplifiers

The I²T 1200 Series Microstepping Drive is a low-cost, compact drive converting step and direction inputs into winding currents for 2-phase stepper motors. Resolution with 1.8° motors is adjustable to 200, 400, 1000, 2000, 5000, 10000, 25000, or 50000 steps/rev with decimal step size selected, and 400, 800, 1600, 3200, 6400, 12800, 25600, or 51200 steps/rev with binary step size selected. Higher resolution (microstepping) provides smoother operation through resonance regions as well as increased position resolution.

The 1200 series drive operates from a single supply voltage ranging from 24Vdc to 75Vdc.

The default output current is 5A Rms. The current can be reduced in increments of 0.625A using a 3-position DIP switch.

A patented 4-phase PWM (pulse width modulated) chopper electronically controls the motor winding currents at 20KHz. This combines the best of recirculating and non-recirculating current regulation to provide high-back EMF rejection with low-ripple current. Benefits include reduced heat dissipation, low electrical noise and improved current control during dynamic braking.

The patented digital electronic damping eliminates motor oscillations common with stepper systems at speeds in the middle of the operating region. This, along with 4-phase chopping, gives significantly more motor output power than competitive systems.

Idle current reduction can be used to reduce motor current by 50% if no step commands have been received for 0.1 second (0.05 and 1.0 sec can also be selected). Current is restored to full amplitude upon arrival of a step command.

The 1200 series drive uses 7.5in² of panel space. The optional side mounted heat sink increases width by 1.0 to 2.5". Heat can be removed from the rear or side of the driver (cold plate mounting) allowing maximum flexibility for system packaging.

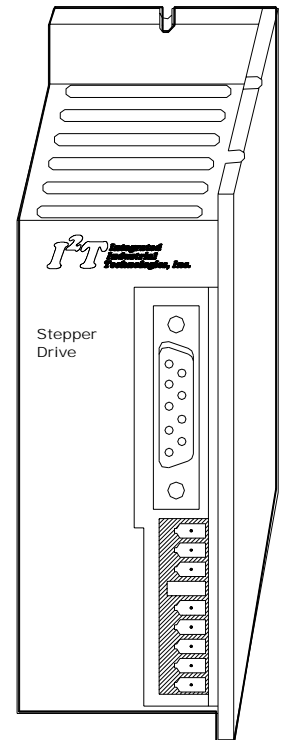

Features & Benefits

- Single Power Supply
- Patented 4-phase Bipolar Chopper Drive for superior current regulation and low-ripple current
- Output current adjustable from 0.625A to 5A Rms with 3-position dipswitch
- Microstepping for smooth operation and increased resolution
- Patented digital electronic damping reduces instability at speeds in middle of operating range
- Idle current reduction to reduce motor heating
- Fault Protection:
 - Line-to-line and Line-to-neutral shorts
 - Internal Power Supply Under-voltage
 - Bus Over-voltage
- Optically Isolated Command Interface:
 - Step
 - Direction
 - Enable
 - Enabled Output
- Selectable Step Filter
 - Rejection of Electrical Noise on Step Input
- Small Size – only 7.5in² of panel space (5" x 1.5" x 4.3")
- UL Recognized

Applications

- X-Y Tables and Slides
- Packaging Machinery
- Robotics
- Specialty Machinery
- Index Feed of Materials
- Labeling Machines

Specifications

Input Power

- Voltage: 24Vdc to 75Vdc
- Current: Motor/Load dependent. Usually < motor phase current
- Output: 5A Rms Max.
- Motor: 5A Peak Full-Step
- Phase: 7.1A Peak Microstepping
- Current: **Note:** Adjustable from 0.625 to 5A Rms in 0.625 Amp increments ([Figure 3](#))

Specifications (Cont'd.)

- **Inputs** (Figure 1 and Figure 2)

STEP

- Optically Isolated TTL Compatible
 - Min. Opto Current (opto on): 5.5 mA
 - Max. Opto Current (opto on): 10 mA
 - Min. Pulse Width: 250 ns (1 μ s)
 - Max. Frequency: 2 MHz (500 KHz)
 - Motion occurs on Low-to-High Transition of STEP Input
- Note:** BOLD values indicate step filter enabled.

DIR

- Optically Isolated TTL Compatible
- For Normal Motor Connections: Current in Opto (opto on) where rotation is CCW looking at motor shaft
- Min. Opto Current (opto on): 3 mA
- Max. Opto Current (opto on): 4.5 mA
- Min. Setup Time: 50.0 μ s
- Min. Hold Time: zero

ENABLE

- Optically Isolated TTL Compatible
- Sense of ENABLE Input can be changed using ENBL_SENSE jumper:
- Jumper In: Current in Opto (opto on) Enables Driver
- Jumper Out: Current in Opto (opto on) Disables Driver
- Min. Opto Current (opto on) 3 mA
- Max. Opto Current (opto on) 4.5 mA

- **Output** (Figure 1 and Figure 2)

ENABLED

- Optically Isolated Open Collector, Open Emitter
- Drive Enabled: Opto Transistor On, where:
 $V_{sat} = 0.5V \text{ max. @ } 2.0 \text{ mA}$
- Drive Disabled: Opto Transistor Off, where
 $V_{ce} \text{ max.} = 35V$

STEP SIZE

 (Figure 3)

Set using 3 Positions of DIP Switch/Decimal Jumper

<u>Step Size</u>	<u>Steps per Revolution</u> (1.8° Motor)
Full (1/2)	200 (400)
1/2 (1/4)	400 (800)
1/5 (1/8)	1000 (1600)
1/10 (1/16)	2000 (3200)
1/25 (1/32)	5000 (6400)
1/50 (1/64)	10000 (12800)
1/125 (1/128)	25000 (25600)
1/250 (1/256)	50000 (51200)

Note: Binary values are in parentheses.

- **Idle Current Reduction** (Figure 3)

- Enabled or Disabled with DIP Switch
- 50% Output Current Reduction after 0.1 sec from Last Step Command
- 0.05 and 1.0 second time-outs can be selected using a plug-on jumper. Consult factory for other current reduction options.

- **Mica-band Instability Compensation**

- Enabled or Disabled with DIP Switch (see Figure 3).
- Max. Delay from Input Step to change in Motor Excitation:
Step frequency < 500 full steps/sec: 500 μ s
Step frequency > 500 full steps/sec: 270° of step period

- **Protection**

- Any fault disables the drive and must be cleared by cycling input power
- Line-to-line Short

Environmental Requirements

- Storage Temperature: -55°C to +70°C
- Operating Temperature: 0 to 50°C Ambient Air w/ or w/o Cover
- Maximum Chassis Temperature: 60°C

Note: For optimal thermal performance, mount the chassis (back or side) to a cooling plate or heat sink. Use a thermal pad or grease if surface is irregular. A fan or idle current reduction may be employed to keep chassis below 60°C.

- Convection Cooling (not mounted on cooling plate)
 - **w/ Heat Sink:** Full rating (5A) at 25°C Ambient, 2.5A max. at 45°C Ambient. Heat Sink is optional.
 - **w/o Heat Sink:** 2.5A max. at 25°C Ambient, 1.25A max. at 45°C Ambient (see Figure 4 for plot of Drive Power Dissipation vs. Output Current)
- Humidity Range: 10 to 90%, Non-conducting

Mechanical

- Dimensions:
 - **w/o Cover:** 5" x 1.5" x 4.3"
 - **w/ Cover & Screws:** 5" x 1.7" x 4.3"
- Weight:
 - 1 lb. Nominal

Connectors (Figure 1)

- Power Supply Motor:
 - 3 Contact Plug-in Screw Terminal
 - 5 Contact Plug-in Screw Terminal
- Signal:
 - 9 Socket "D" Sub-miniature

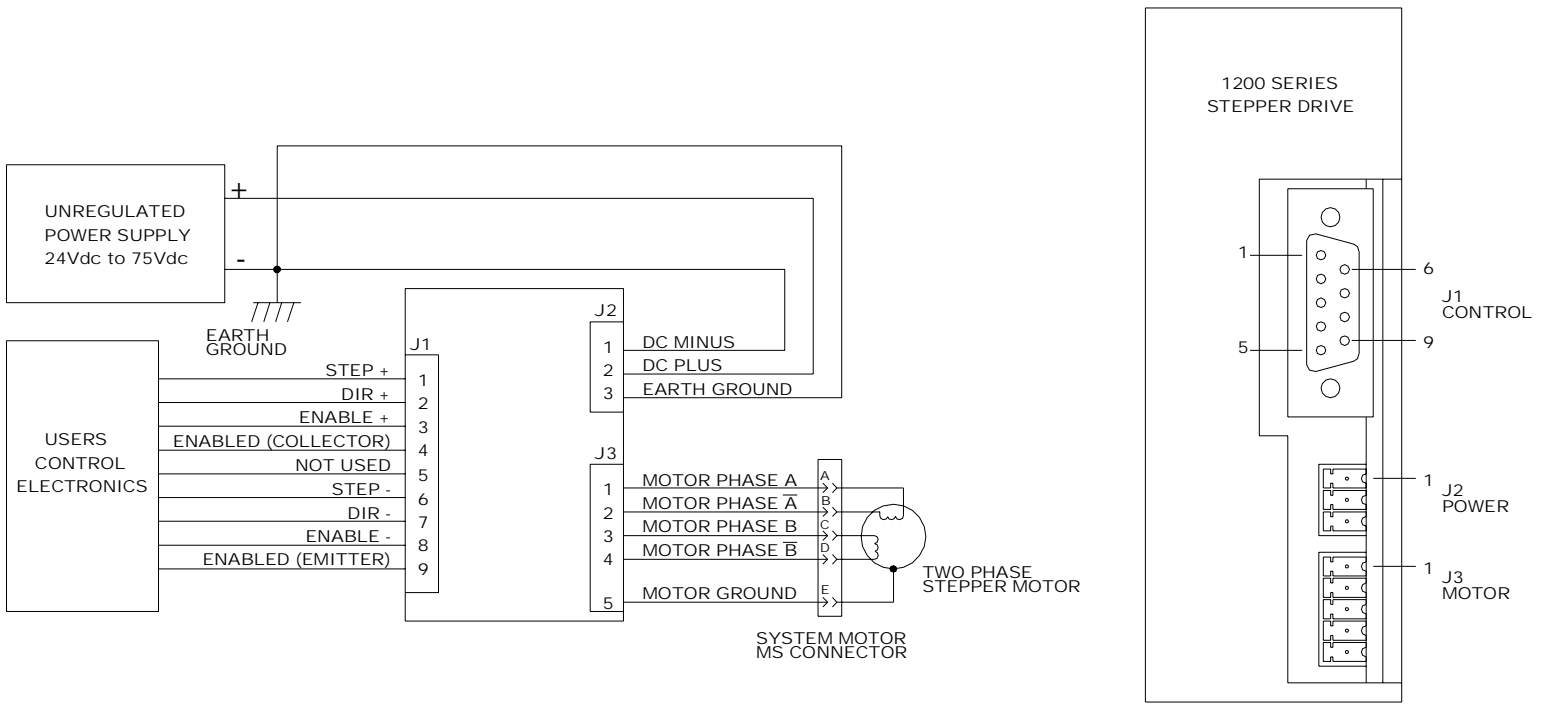

Figure 1: 1200 Series Amplifier Connections

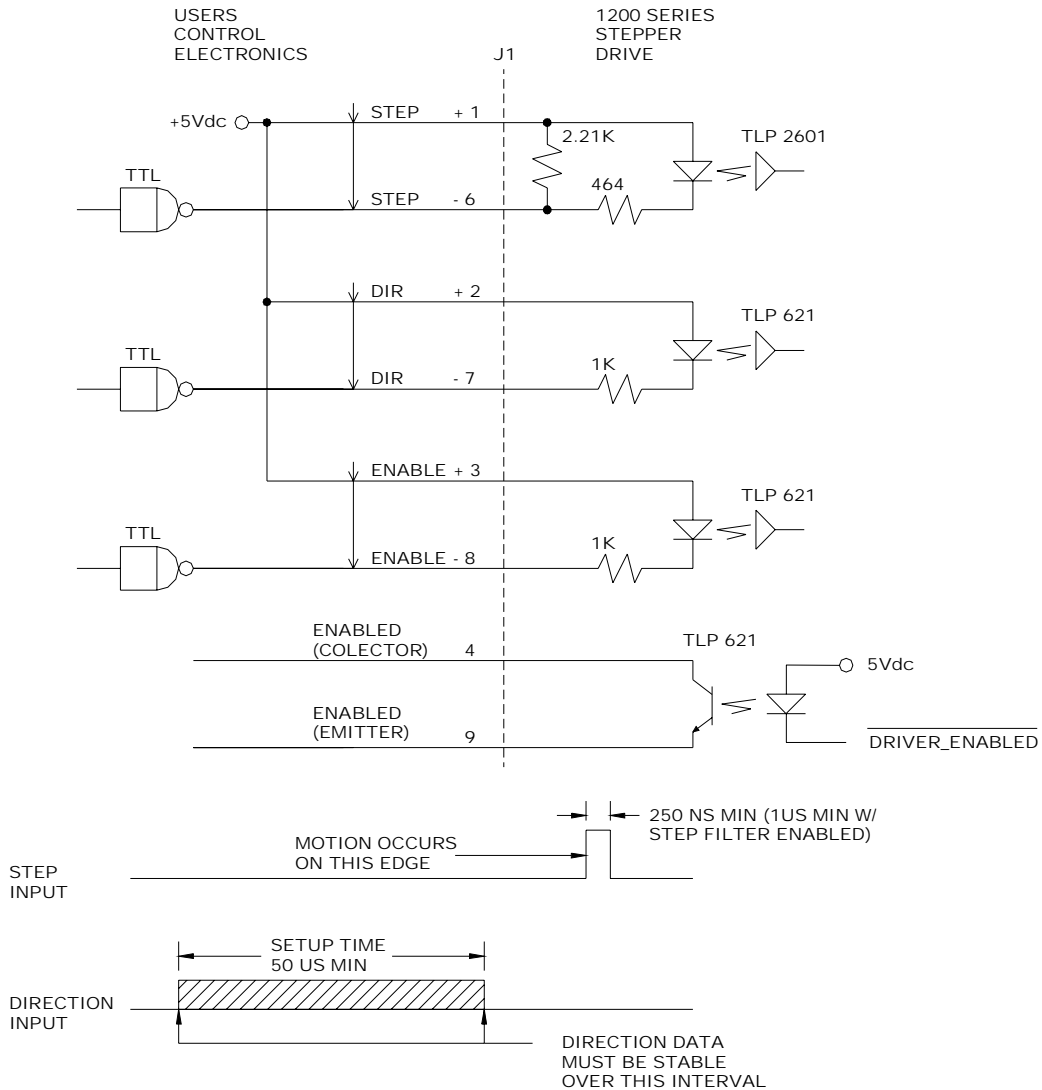

Figure 2: Interface Circuits

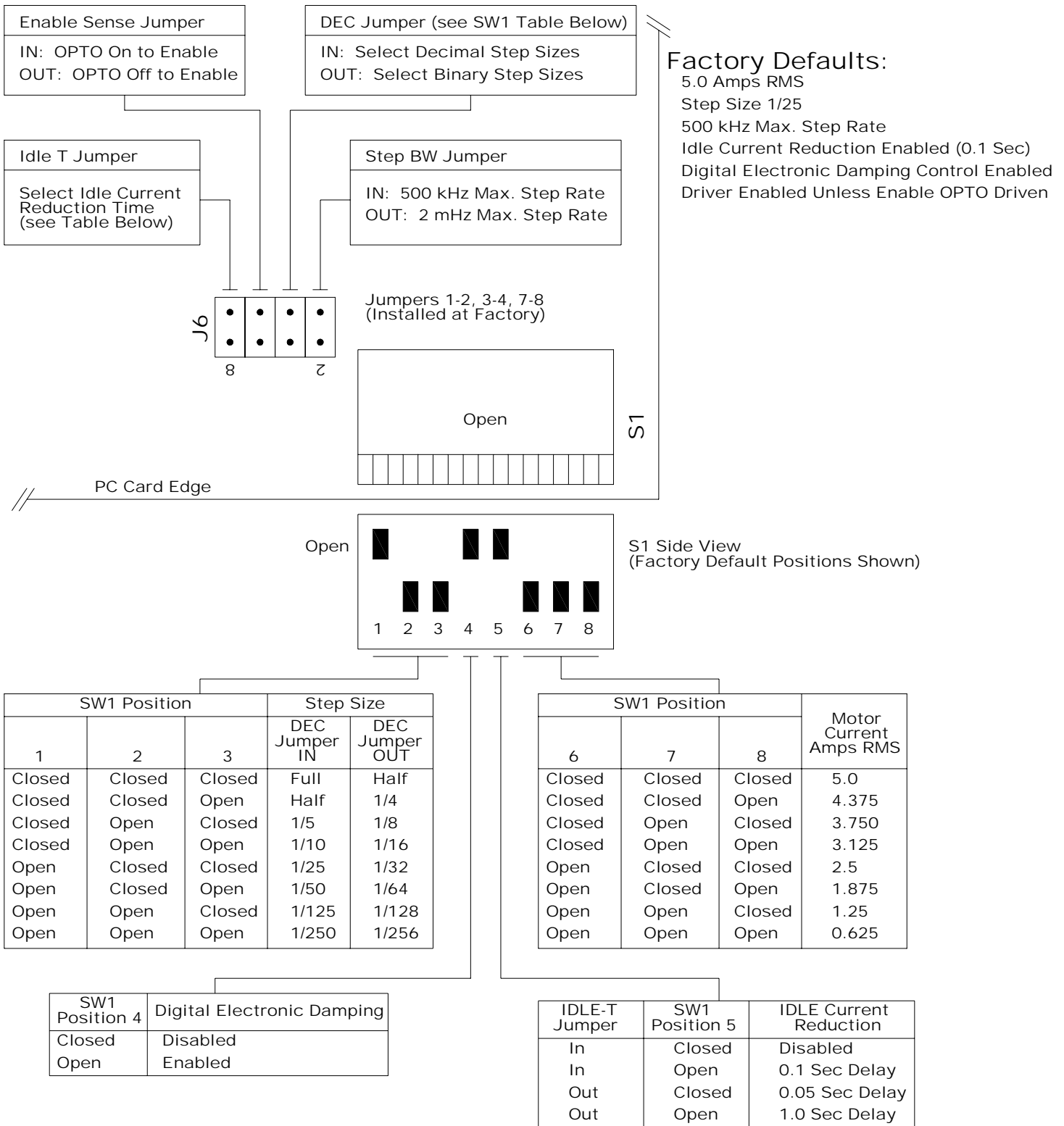

Figure 3: DIP Switch Settings (S1)

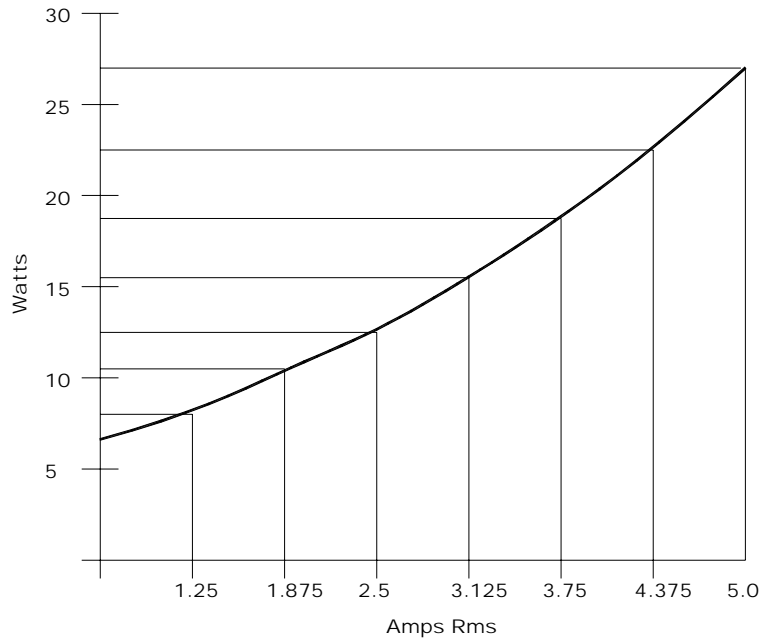

Figure 4: Power Dissipation vs. Output Current

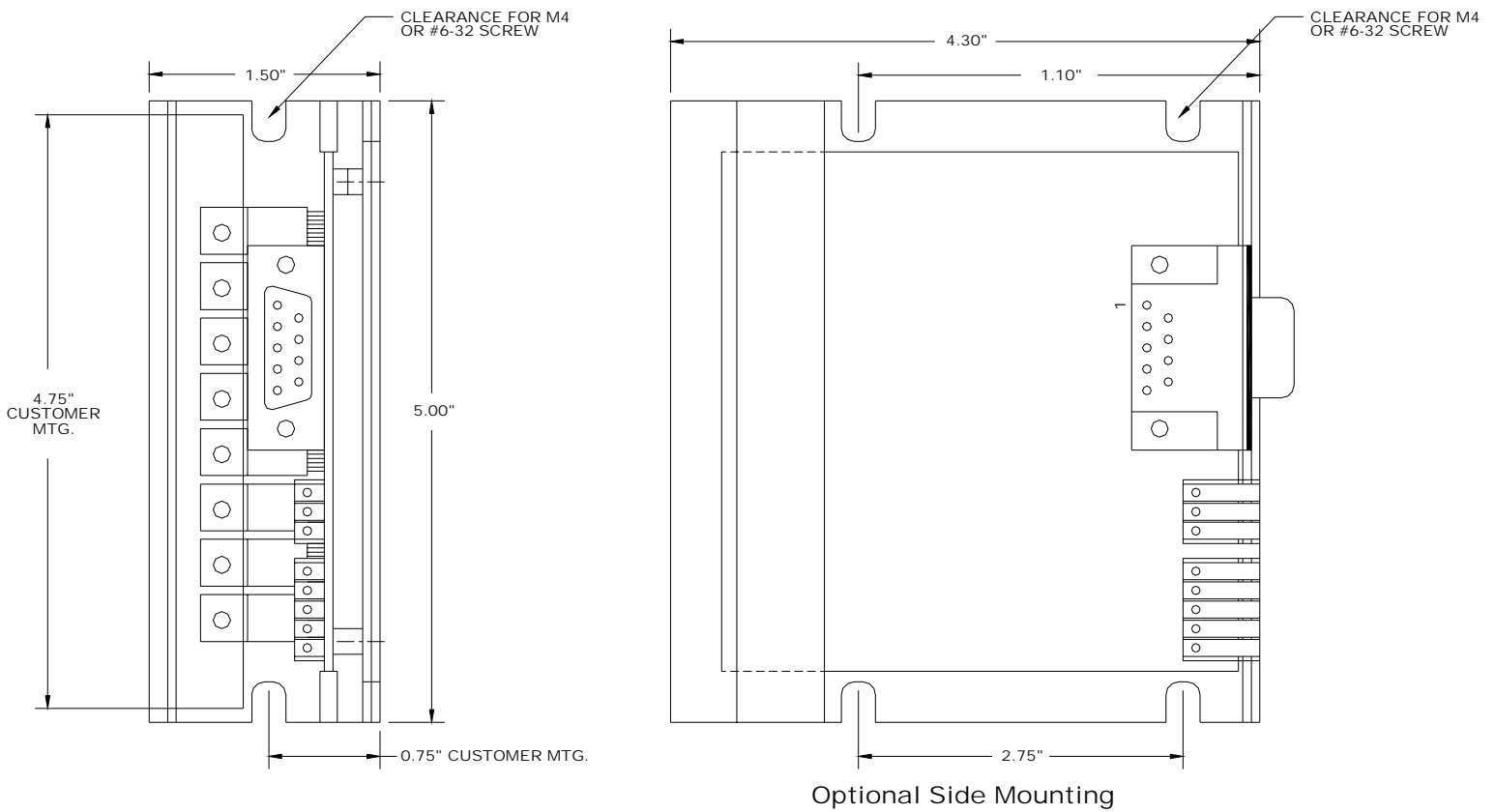
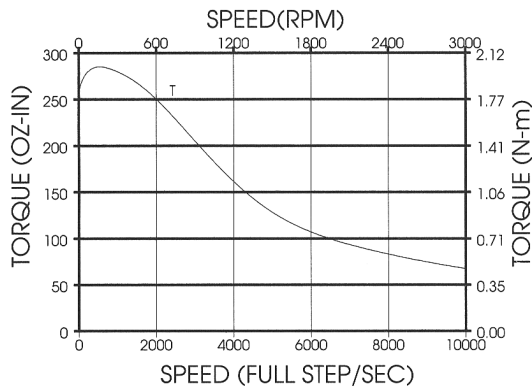

Figure 5: Mounting Dimensions

TORQUE/SPEED CURVES w/ RECOMMENDED MOTORS (for 2.5A and 5.0A Operation)

Motors will perform as shown without the winding temperature exceeding a rise of 90°C when the motor is operated unmounted (w/o heat sink) in an ambient temperature of up to 40°C. The curves do not reflect systems resonance points which will vary with motor coupling and systems parameters. In addition to those shown, I²T offers motor windings to meet specific performance requirements. Consult factory.



Curve A: 3" Motor-One Rotor Stack (5.0A / 65V per Phase)

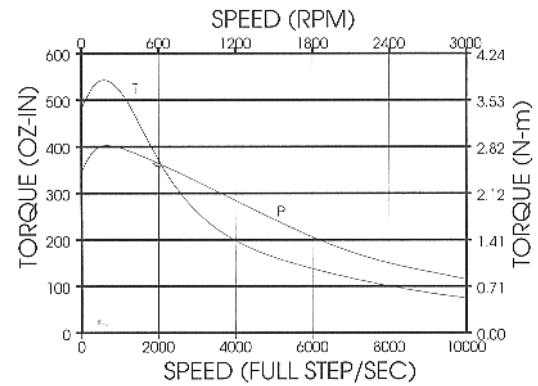

Curve B: 3" Motor-Two Rotor Stacks (5.0A / 65V per Phase)

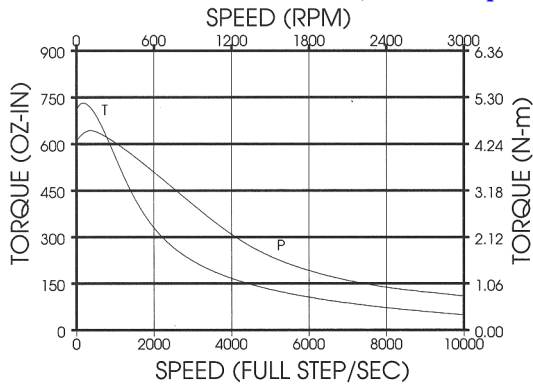

Curve C: 3" Motor-Three Rotor Stacks (5.0A / 65V per Phase)

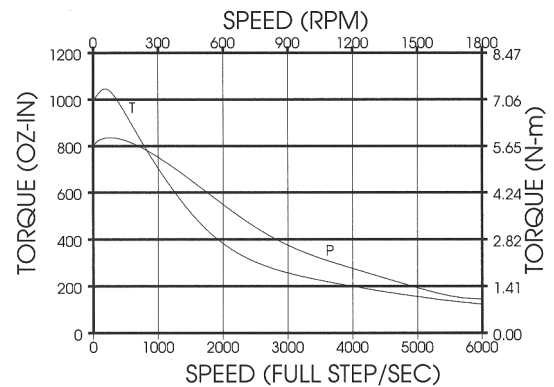

Curve D: 3" Motor-Four Rotor Stacks (5.0A / 65V per Phase)

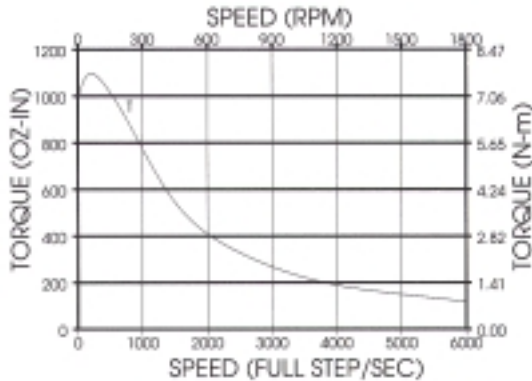

Curve E: 4" Motor-One Rotor Stack (5.0A / 65V per Phase)

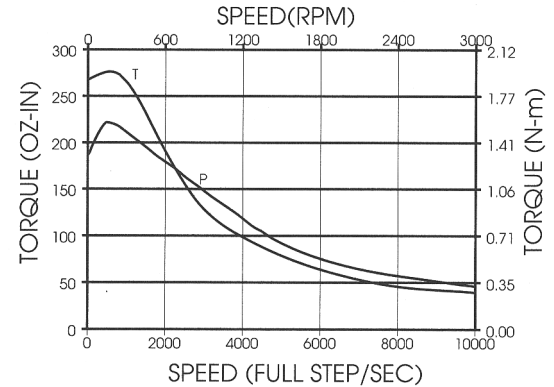

Curve F: 3" Motor-One Rotor Stack (2.5A / 65V per Phase)

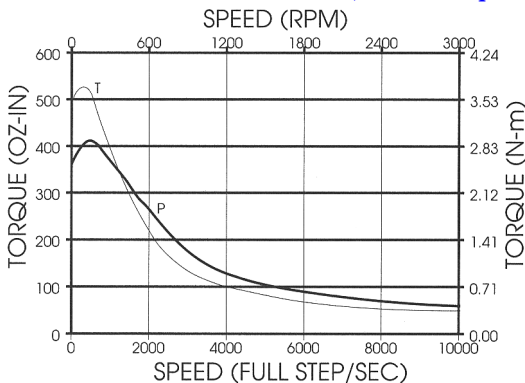

Curve G: 3" Motor-Two Rotor Stacks (2.5A / 65V per Phase)

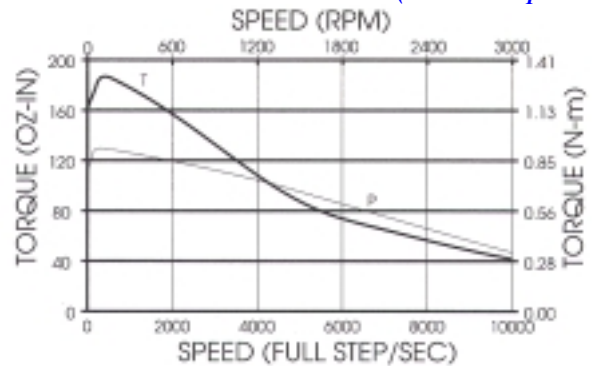

Curve H: 2" Motor-Two Rotor Stacks (2.5A / 65V per Phase)