

Innovative Ideas In Motion

Automobile Painting Robot

I²T designed the control system and wrote the application software for an eleven axis profiling automobile painting robot.

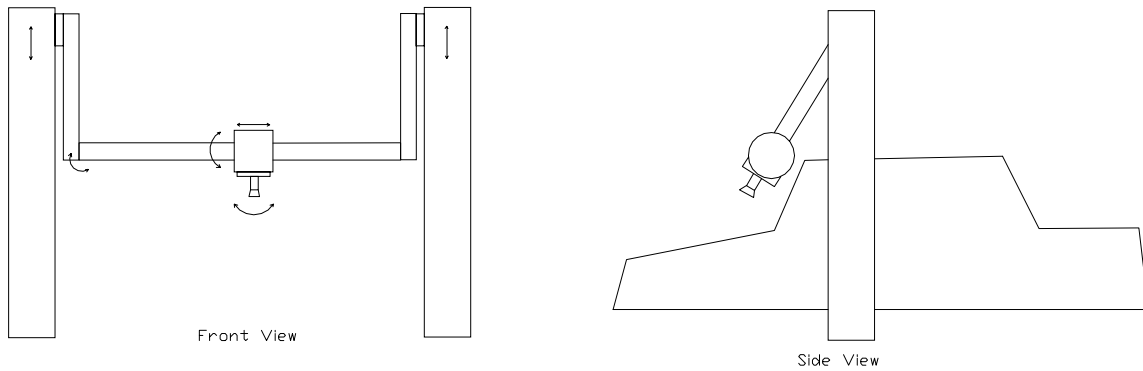

The following shows a block diagram of the control hardware used.

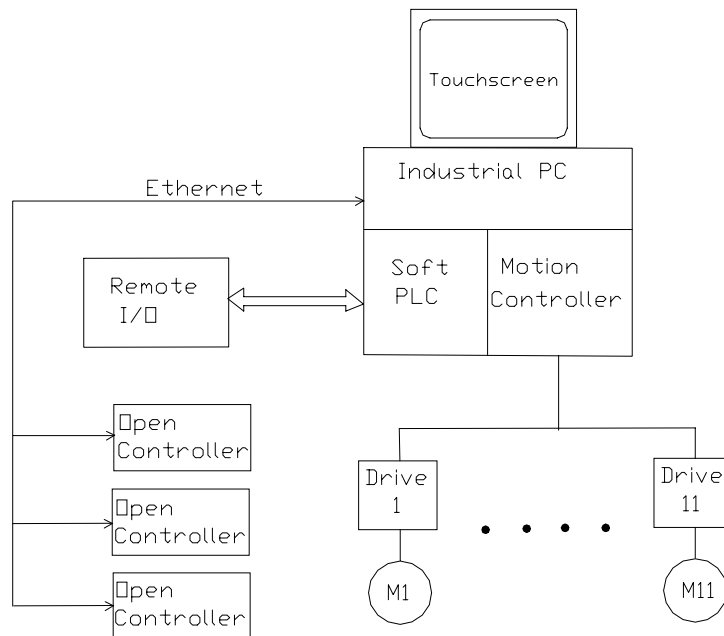

The painting system is broken into three systems: a sixteen-axis U600 motion control board, a soft PLC, and three paint controllers. The paint controllers handle the composition and flow of paint through the applicators to each paint head. The motion control positions the applicators along the car body. The PLC is Allen-Bradley SoftLogix (software PLC) and it handles data storage, primary user interface, and sequencing of the system. The motion control and PLC applications reside in a single industrial PC, communicating to the paint controllers via Ethernet.

The painting system has three heads: left, right, and top. The axes of each head are grouped together into control machines. Each machine can operate independently or synchronously. As cars are being painted, all three heads synchronously follow the contour of the car.

A car body is defined by a series of points in space, which represent the surface of the car frame. The user interface allows the operator to define the car surface by entering specific points on the surface. The motion application takes these defined points and generates a surface of uniformly distant points from the car body. The car is continuously moving on a conveyor as it is being painted. While the car is moving by, the paint system follows a precise pattern back and forth along the contour of the car, while also following the speed of the conveyor. While painting is occurring, the spray head of each machine is kept normal to the surface being painted, allowing a uniform application of paint to the surface.