



221 Seventh Street, Suite 200, Pittsburgh, PA 15238
(412) 828-1200
www.isquaredt.com

BM & BMS Series Brushless Motor User's Guide 5002-01



Revision 1.1
08/08/01

Integrated Industrial Technologies, Inc.
221 Seventh Street, Suite 200
Pittsburgh, PA 15238

Phone (412) 828-1200

Fax (412) 828-0320

WEB: <http://www.isquaredt.com>

BM & BMS SERIES USER'S MANUAL _____ CONTENTS

1. Chapter 1	1-1
1.1. BM Series Brushless Motor	1-1
1.2. BM Series Models	1-2
1.3. BMS Series Models.....	1-2
1.4. Hardware Overview	1-2
1.5. Encoder Hall Effect Commutation	1-2
1.6. Resolver Commutation	1-4
1.7. Part Number and Ordering Information.....	1-6
1.8. Motor Specifications.....	1-7
1.9. Feedback Device Specifications.....	1-11
1.10. Encoder Specifications	1-11
1.11. Connector Pinouts	1-12
1.12. Brushless Motor Dimensions	1-13
2. Chapter 2	2-1
2.1. Warranty	2-1
2.2. Return Policy	2-1
2.3. Technical Support	2-1
2.4. Assumptions	2-2
2.5. Shipment Inspection.....	2-2

In this Chapter you will learn about:

- Product Overview
- BM Series Models
- BMS Series Models
- Hardware Overview
- Encoder Hall Effect Commutation
- Resolver Commutation
- P/N and Ordering
- BM Motor Specifications
- Connector Pinouts

1.1. BM Series Brushless Motor

The BM Series Brushless Motor provides 50% more torque, 15 times the acceleration, and 33% shorter length than brush DC servo motors. Unlike DC servo motors, the BM series motors require no maintenance. The BM series motors can attain a top speed to 10,000 RPM and a rated speed up to 4,000 RPM. Available to each motor is a 24 Vdc fail-safe holding brake that is engaged when power is disabled. This brake is very useful in vertical lift applications.



Figure 1-1: BM & BMS Series Brushless Motor

1.2. BM Series Models

The BM series motors are available in ten different models with a rated power from 200 to 2330 watts and torque ranging from 75 oz-in (0.5 N-m) to 1400 oz-in (10 N-m).

1.3. BMS Series Models

The BMS series motors are available in two different models with a rated power from 175 to 217 watts and torque ranging from 59 oz-in (0.4 N-m) to 98 oz-in (0.7 N-m).

1.4. Hardware Overview

The BM series are smaller and weigh less than brush or stepper motors of the same power capacity. The motors feature standard NEMA frame sizes allowing easy replacement of stepping motors. The motors have skewed stator laminations that provide smooth velocity control. Signal and motor power connections are made through separate MS-style connectors.

The BMS series motors are manufactured with a slot less design and exhibit extremely smooth velocity regulation.

1.5. Encoder Hall Effect Commutation

The BM and BMS series brushless rotary motors are shipped from the factory with the correct motor phase to Hall effect device relationship established. This is essential for proper motor commutation.

Figure 1-2 shows the proper Hall effect to motor phasing for both clockwise (CW) and counterclockwise (CCW) motor rotation (viewed looking into the mounting flange of the motor).

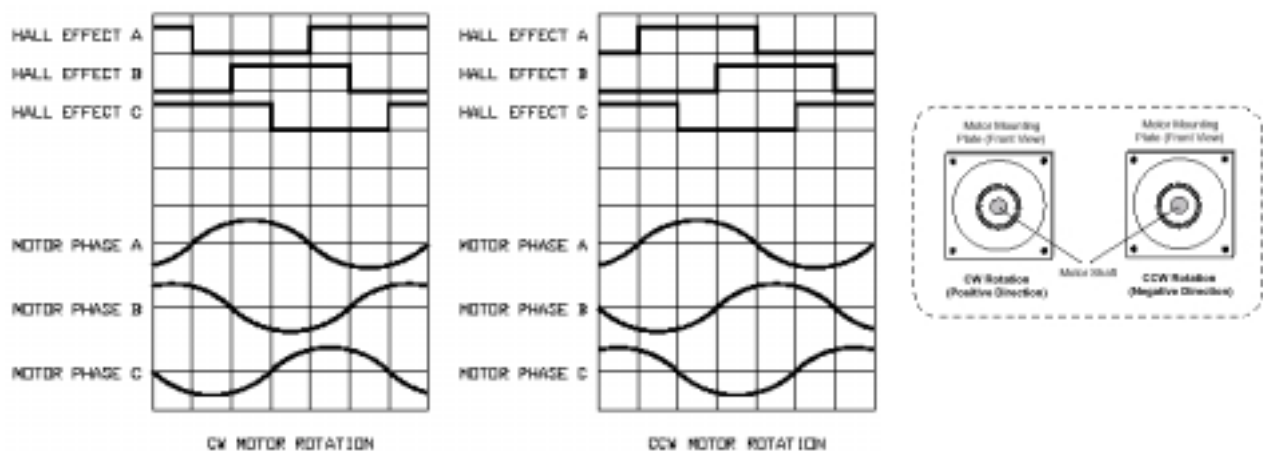

Figure 1-2: Hall Effect and Motor Phasing

NOTE 📌 During CW motor rotation, each Hall effect signal is at a logic low state when its corresponding motor phase is at a positive voltage. During CCW rotation, each Hall effect signal is at a logic high state when its corresponding motor phase is at a positive voltage.

The waveforms created by the motor phasing can be observed using a Wye resistor network, a dual-trace oscilloscope, and by performing the following steps.

WARNING 🚫 **Motor voltage is monitored without power applied to the motor.**

Before performing the following steps, remove all connections to the motor except the wye resistor network. Remove all mechanical connections to the motor shaft.

1. Connect the ends of three resistors to motor terminals, A, B, C (see *Figure 1-3*).
2. Use one channel of the oscilloscope to monitor motor terminal A with respect to the “Wye” neutral (the point where all resistors are connected together) refer to *Figure 1-3*.
3. Connect a 5V power supply to the power pins of the encoder (see *Figure 1-4*).
4. Connect the second channel of the oscilloscope to Hall effect A on the encoder.
5. Once the oscilloscope is connected with one probe monitoring a motor phase and the other monitoring a Hall effect signal, rotate the motor by hand using the motor shaft. The motor will generate a voltage upon rotation.
6. Observe the phase relationship of the motor phase to the Hall effect signal.

NOTE 📌 **It is necessary for the voltage generated by the motor phase A to be in phase with the signal used as Hall effect A (see *Figure 1-2*).**

7. Move the probe on the Hall effect line to the other two Hall effect lines, observing their phase relationship to the motor voltage.
8. Repeat this process for the other two motor phases.

Using this procedure, connect the Hall effect signals with the appropriate motor phases as seen in *Figure 1-2*.

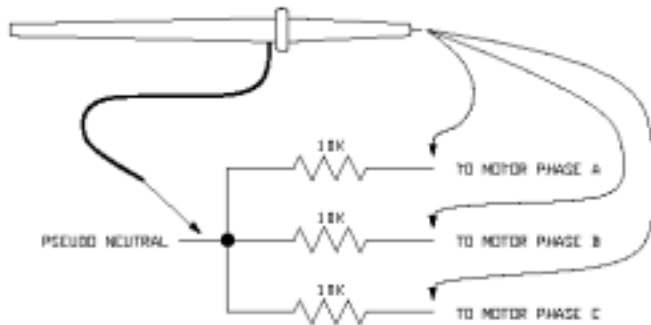

Figure 1-3: Motor Phase Voltage Observation Scheme

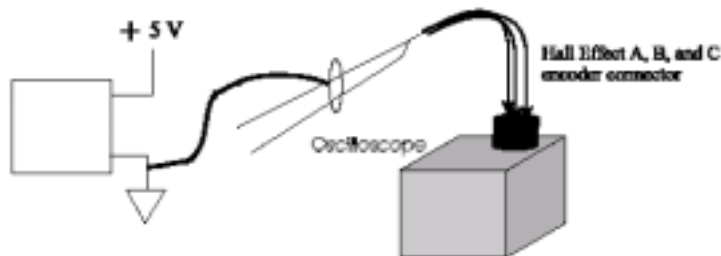

Figure 1-4: Encoder Phase Voltage Observation Scheme

1.6. Resolver Commutation

An optional resolver can be used as the feedback device for a brushless rotary motor. The resolver is aligned at the factory, so that the null position of the resolver corresponds to a motor phase angle of zero degrees (*Figure 1-5*). The null position of the resolver is considered to be the point at which the sine feedback signal is resting at a zero level and the cosine signal is resting at its positive peak.

NOTE ⚡ The sine and cosine signals shown in *Figure 1-5* represent demodulated waveforms. In actual operation, these signals are transmitted on a high frequency carrier (i.e., 5kHz, 10kHz).

The zero degree phase angle of the motor is defined as the position that the motor shaft will align to if phase A is energized with a positive voltage with respect to phase B and phase C. The 8 pole motors (4 pole pairs) have 4 zero degree points per revolution, and the 6 pole motors have 3 zero degree points per revolution.

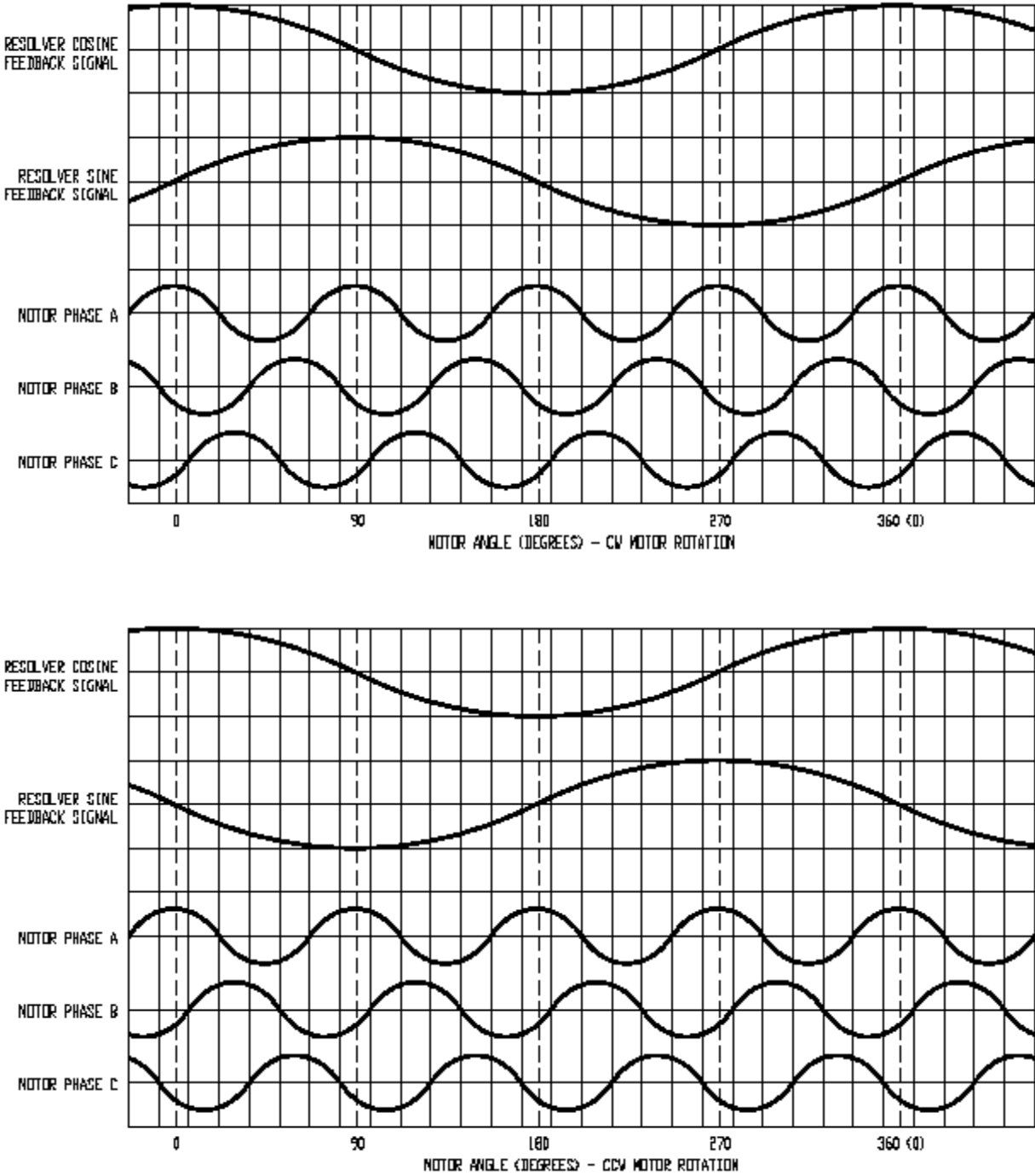

Figure 1-5: Resolver and Motor Phasing

1.7. Part Number and Ordering Information

Order information regarding part numbers and descriptions are shown in *Figure 1-6*.

Model	Description
BM75-MS-E1000H	75 oz-in (0.5 N-m) brushless servo motor, end cover, encoder
BM130-MS-E1000H	140 oz-in (1.0 N-m) brushless servo motor, end cover, encoder
BM200-MS-E1000H	200 oz-in (1.4 N-m) brushless servo motor, end cover, encoder
BM250-MS-E1000H	275 oz-in (1.9 N-m) brushless servo motor, end cover, encoder
BM500-MS-E1000H	510 oz-in (3.6 N-m) brushless servo motor, end cover, encoder
BM800-MS-E1000H	780 oz-in (5.5 N-m) brushless servo motor, end cover, encoder
BM1400-MS-E1000H	1365 oz-in (9.6 N-m) brushless servo motor, end cover, encoder
BM2000-MS-E1000H	130 lb-in (14.7 N-m) brushless servo motor, end cover, encoder
BM3400-MS-E1000H	210 lb-in (23.7 N-m) brushless servo motor, end cover, encoder
BM4500-MS-E1000H	280 lb-in (31.5 N-m) brushless servo motor, end cover, encoder
BMS60-A-D25-E1000H	59 oz-in (0.4 N-m) brushless “slot less” servo motor, end cover, encoder
BMS100-A-D25-E1000H	98 oz-in (0.7 N-m) brushless “slot less” servo motor, end cover, encoder

Figure 1-6: Order Information

1.8. Motor Specifications

The specifications for the BM series brushless motors are located in *Table 1-1* and *Table 1-2*. Specifications for the BMS series motors are listed in *Table 1-3*.

Model	Units	BM75	BM130	BM200	BM250	BM500
Continuous Stall Torque	Oz-in	75	140	200	275	510
	N-m	0.53	1.0	1.41	1.94	3.6
Peak Torque	Oz-in	200	350	500	700	1275
	N-m	1.41	2.5	3.5	5.0	9.0
Maximum Speed	Rpm	10,000	10,000	8,000	8,000	8,000
Rated Speed	Rpm	4,000	4,000	4,000	4,000	4,000
Rated Power	Hp	0.28	0.39	0.60	0.8	1.5
	Watts	210	290	450	590	1100
Torque Constant (stall)	Oz-in/amp(RMS)	12.5	31.1	28.6	39.3	39.2
	N-m/amp(RMS)	0.08	0.22	0.20	0.28	0.28
Continuous Stall Current (max.)	A (peak)	8.5	6.3	10	10.0	18
Continuous Stall Current	A (RMS)	6.0	4.5	7.0	7.0	13.0
Peak Current (max.)	A (peak)	26	19	30	30	55
Peak Current (RMS)	A (RMS)	18	14	21	21	39
Back EMF Constant (line-line)	Volts (peak)/Krpm	7.5	18.7	17.2	23.8	23.6
Terminal Resistance (line-line)	Ohms (cold)	1.0	2.0	1.1	1.1	0.5
Armature Inductance (line-line)	MH	0.8	1.8	1.1	1.3	2.8
Inertia	oz-in-sec ²	0.0007	0.0013	0.0019	0.011	0.020
	kg-m ²	0.52x10 ⁻⁵	0.92x10 ⁻⁵	1.3x10 ⁻⁵	7.8x10 ⁻⁵	13.9x10 ⁻⁵
Maximum Acceleration	Rad/sec ²	270000	270000	270000	60000	65000
Recommended Bus Voltage	Volts	160	160	160	160	160
Motor Constant	Oz-in/Watt ^{1/2}	8.3	15	19	25	39
	N-m/Watt ^{1/2}	0.06	0.10	0.13	0.18	0.27
Static Friction Torque	Oz-in	2	3	4	5	10
	N-m	0.01	0.02	0.03	0.04	0.07
Number of Poles		8	8	8	8	8
Maximum Winding Temp	Deg C	155	155	155	155	155
Electrical Time Constant	Msec	0.8	0.9	1.1	1.2	6.1
Thermal Time Constant	Min	10	11	12	18	24
Thermal Resistance	Deg C/Watt	1.54	1.4	1.09	1.05	0.75
Motor Sealing		None	None	None	IP65	IP65
Front Shaft Seal		None	None	None	Optional	Optional
Shaft Runout	Inch	0.001	0.001	0.001	0.001	0.001
	Mm	0.025	0.025	0.025	0.025	0.025
Maximum Radial Load	Lb.	20	20	20	40	40
	N	89	89	89	178	178
Maximum Axial Load	Lb.	20	20	20	20	20
	N	889	889	889	889	889
Operating Temperature	Deg C	0 to 40	0 to 40	0 to 40	0 to 40	0 to 40
Storage Temperature	Deg C	-20 to 85	-20 to 85	-20 to 85	-20 to 85	-20 to 85
Nema Frame Size		23	23	23	34	34
Motor Weight	Lb	2.5	3.3	4.3	8	11
	Kg	1.1	1.5	2.0	3.6	5.0

Table 1-1: BM Motor specifications (BM75 – BM500)

Chapter 1 BM & BMS SERIES OVERVIEW

Model	Units	BM800	BM1400
Continuous Stall Torque	Oz-in	780	1365
	N-m	5.5	9.6
Peak Torque	Oz-in	2000	3400
	N-m	14	24
Maximum Speed	Rpm	6000	6000
Rated Speed	Rpm	3000	3000
Rated Power	Hp	1.9	3.1
	Watts	1400	2330
Torque Constant (stall)	Oz-in/amp(RMS)	105	105
	N-m/amp(RMS)	0.74	0.74
Continuous Stall Current (max.)	A (peak)	10.6	18
Continuous Stall Current	A (RMS)	7.5	13.0
Peak Current (max.)	A (peak)	33	55
Peak Current (RMS)	A (RMS)	23	39
Back EMF Constant (line-line)	Volts (peak)/Krpm	62	62
Terminal Resistance (line-line)	Ohms (cold)	1.2	0.5
Armature Inductance (line-line)	MH	3.8	1.7
Inertia	oz-in-sec ²	0.042	0.080
	kg-m ²	30x10 ⁻⁵	56x10 ⁻⁵
Maximum Acceleration	Rad/sec ²	46000	42000
Recommended Bus Voltage	Volts	320	320
Motor Constant	Oz-in/Watt ^{1/2}	58	98
	N-m/Watt ^{1/2}	0.4	0.7
Static Friction Torque	Oz-in	15	35
	N-m	0.1	0.3
Number of Poles		8	8
Maximum Winding Temp	Deg C	155	155
Electrical Time Constant	Msec	3.1	3.4
Thermal Time Constant	Min	35	40
Thermal Resistance	Deg C/Watt	0.8	0.66
Motor Sealing		IP65	IP65
Front Shaft Seal		Optional	Optional
Shaft Runout	Inch	0.001	0.001
	Mm	0.025	0.025
Maximum Radial Load	Lb.	50	50
	N	222	222
Maximum Axial Load	Lb.	20	20
	N	889	889
Operating Temperature	Deg C	0 to 40	0 to 40
Storage Temperature	Deg C	-20 to 85	-20 to 85
Nema Frame Size		42	42
Motor Weight	Lb	14.5	23.5
	Kg	6.6	10.7

Table 1-2: BM Motor Specifications (BM800 – BM1400)

Model	Units	BM2000	BM3400	BM4500
Continuous Stall Torque	N-m (lb-in)	14.7 (130)	23.7 (210)	31.5 (280)
Peak Torque	N-m (lb-in)	43.9 (390)	70.8 (630)	94.8 (840)
Maximum Speed	Rpm	2,700	2,700	2,700
Rated Speed	Rpm	2,400	2,400	2,400
Rated Power	Watts (hp)	3,282 (4.4)	5,073 (6.8)	6,789 (9.1)
Continuous Stall Current	Amp _{pk}	16.8	27.8	37.1
	Amp _{rms}	11.9	19.7	26.2
Torque Constant	N-m/Amp _{pk}	0.87	0.85	0.85
	Lb-in/Amp _{pk}	7.7	7.5	7.5
	N-m/Amp _{rms}	1.2	1.2	1.2
	Oz-in/Amp _{rms}	10.9	10.6	10.6
BEMF Constant	Volts _{pk} /krpm	99.0	99.0	99.0
Resistance, 25°C, line-line	Ohms	0.66	0.24	0.13
Inductance, line-line	MH	4.7	2.0	1.4
Rotor Moment of Inertia	Kg-m ²	0.00119	0.00212	0.00308
	Lb-in-sec ²	0.0106	0.0188	0.0273
Maximum Acceleration	Rad/sec ²	40,265	32,675	29,094
Recommended Bus Voltage	VDC	320	320	320
Number of Poles		6	6	6
Motor Weight	Kg (lb)	16.3 (36.0)	23.1 (51.0)	29.9 (66.0)
Motor Constant	N-m/√W	0.92	1.50	2.00
	Oz-in/√W			
Max Radial Load	N (lb)	668 (150)	668 (150)	668 (150)
Max Axial Load	N (lb)	223 (50)	223 (50)	223 (50)
Operating Temperature	°C	0 to 40	0 to 40	0 to 40
Storage Temperature	°C	-20 to 85	-20 to 85	-20 to 85

Table 1-3: BM Motor Specifications (BM2000 – BM4500)

Chapter 1 BM & BMS SERIES OVERVIEW

Model	Units	BMS60	BMS100
Winding Designation		-A	-A
Continuous Stall Torque	N-m (oz-in)	0.42 (59)	0.69 (98)
Peak Torque	N-m (oz-in)	1.68 (238)	2.76 (391)
Max Peak	Rpm	10,000	10,000
Rated Speed	Rpm	4,000	3,000
Rated Power	Watts (hp)	175 (0.23)	217 (0.29)
Continuous Stall Current	Amp _{pk}	2.6	2.2
	Amp _{rms}	1.8	1.5
Torque Constant	N-m/Amp _{pk}	0.16	0.32
	Oz-in/Amp _{pk}	22.7	45.3
	N-m/Amp _{rms}	0.23	0.45
	Oz-in/Amp _{rms}	32.1	64.1
BEMF Constant	Volts _{pk} /krpm	19.4	38.3
Cold Resistance, line-line	Ohms	7.2	11.4
Inductance, line-line	mH	1.1	2.2
Rotor Moment of Inertia	Kg-m ²	1.96x10 ⁻⁵	3.71x10 ⁻⁵
	Oz-in-sec ²	0.0028	0.0053
Max Acceleration	Rad/sec ²	85,000	74,000
Recommended Bus Voltage	VDC	160	160
Motor Constant	N-m/√W	0.061	0.095
	Oz-in/√W	8.64	13.45
Motor Weight	Kg (lb)	1.1 (2.5)	1.5 (3.3)
Max Radial Load	N (lb)	89 (20)	89 (20)
Max Axial Load	N (lb)	89 (20)	89 (20)
Operating Temperature	°C	0 to 40	0 to 40
Storage Temperature	°C	-20 to 85	-20 to 85

Table 1-4: BMS Motor Specifications (BMS60 – BMS100)

NOTE ⚡ Specifications at 25°C ambient. BMS60, BMS100, BM75, BM130, BM200, BM250, BM500 mounted to 10 x 10 x 0.25” (254 x 254 x 6mm) heatsink. BM800, BM1400 mounted to 12 x 12 x 0.5” (305 x 305 x 13mm) heatsink.

Motor weight includes encoder and end cover.

De-rate continuous torque by 10% when using encoder.

1.9. Feedback Device Specifications

Table 1-5 contains the encoder specifications for the BM series brushless motors and Figure 1-7 shows the phasing of sine, cosine, and marker channels for rotary encoders.

1.10. Encoder Specifications

Parameters	Values
Input Power	5VDC @ 400 mA max
Sink/Source Current	20 mA
Output Configuration	Differential line driver (26LS31)
Output Frequency	100KHz (all channels)
Operating Temperature	-10°C to 85°C
Storage Temperature	-30°C to 110°C
Resolution	1000 Cycles/rev
Commutation	4 Cycles/rev

Table 1-5: Encoder Specifications

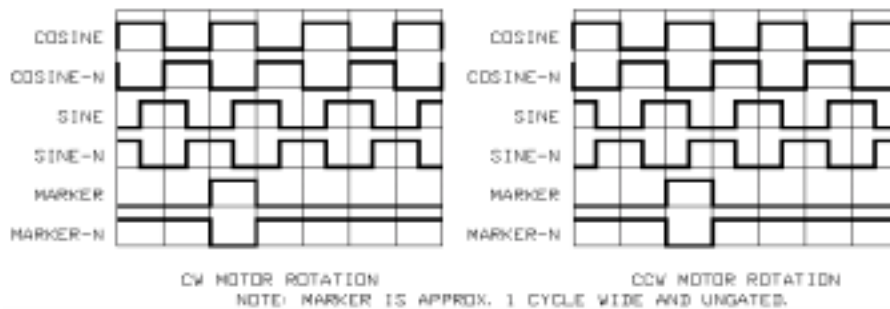

Figure 1-7: Phasing of Sine, Cosine and Marker Channels for Rotary Encoder

Table 1-6 contains the resolver specifications. For phase relationships of resolver feedback signals, refer to Figure 1-5.

Parameters	Units	5KHz Operation	10KHz Operation
Input Voltage	Volts _{rms}	7	7
Input Current	MA	70 Max	50 Max
Input Power	Watts	0.31 Max	0.20 Max
Transformer Ratio	Output/Input	0.5	0.5
Phase Shift	Deg °	17 ±3	4 Max
Rotor DC Resistance	Ohms	40	40
Stator DC Resistance	Ohms	77	77
Null Voltage	MV	20	20
Electrical Error	Arc Min	±15	±15
Output Voltage	Volts _{rms}	3.5	3.5
Operating Temperature	°C	-55 to 155	-55 to 155

Table 1-6: Resolver Specifications

1.11. Connector Pinouts

PIN	Function
A	Motor Phase A
B	Motor Phase B
C	Motor Phase C
D	Motor Frame Ground

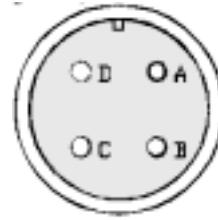

Figure 1-8: Motor Power Connector (MS3101A-10P)

PIN	Function	PIN	Function
A	Cosine	L	Hall Effect A-N
B	Cosine-N	M	Hall Effect B
C	Sine	N	Hall Effect B-N
D	Sine-N	P	Hall Effect C
E	Marker	R	Hall Effect C-N
F	Marker-N	S	Brake+ (optional)*
G	Common	T	Brake- (optional)*
H	+5V		
J	Shield (NC to frame)		
K	Hall Effect A		

* 24VDC @ 1A max.

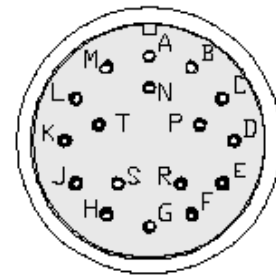

Figure 1-9: Encoder Connector (MS3101A-20-29P)

PIN	Function	PIN	Function
A	Sine+	L	
B	Sine-	M	
C	Cosine+	N	Sine Shield (NC to frame)
D	Cosine-	P	Cosine Shield (NC to frame)
E	Ref+	R	Reference Shield (NC to frame)
F	Ref-	S	Brake+ (optional)*
G		T	Brake- (optional)*
H			
J			
K			

* 24VDC @ 1A max.



Figure 1-10: Resolver Connector (MS3101A-20-29P)

1.12. Brushless Motor Dimensions

The following figures show the outline dimensions of each model in the BM series brushless motors.

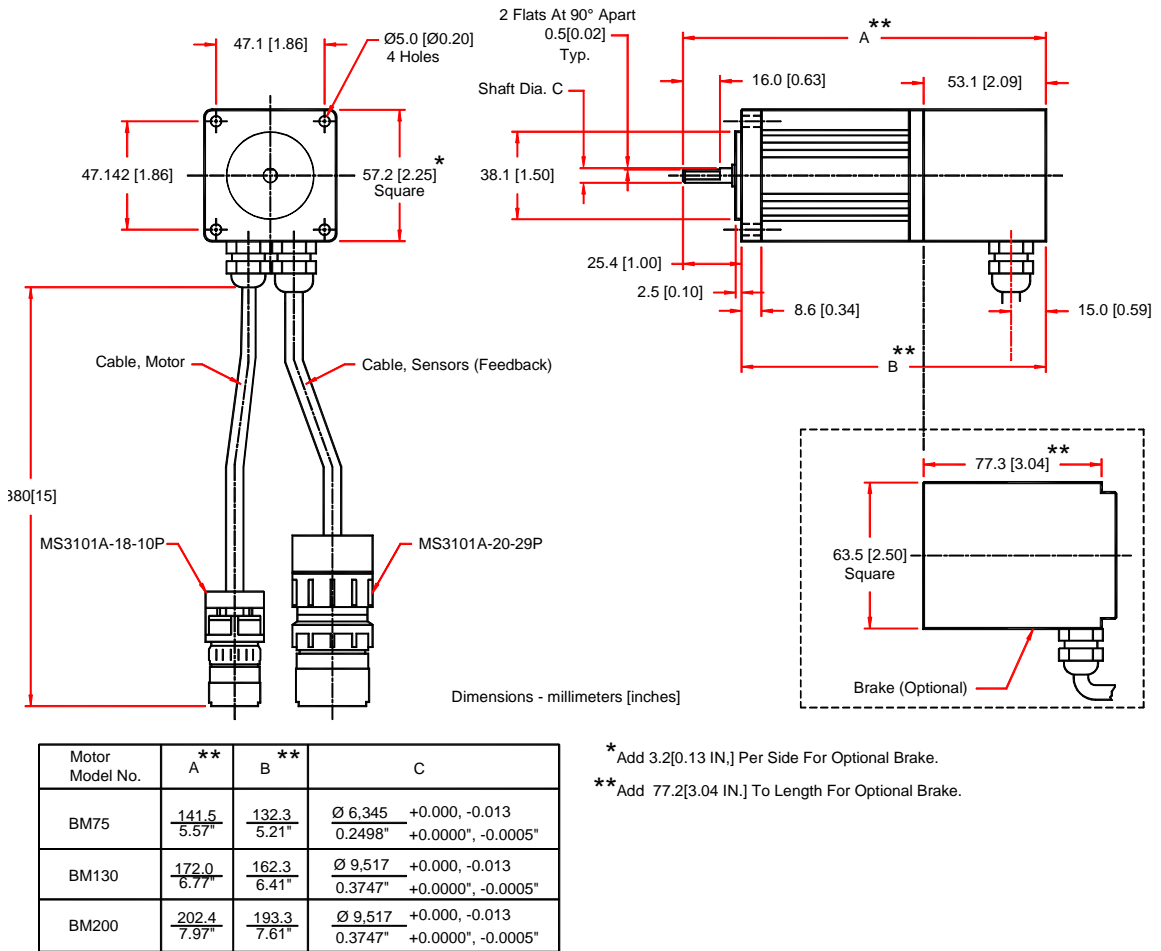

Figure 1-11: BM75, BM130, BM200 Model Dimensions

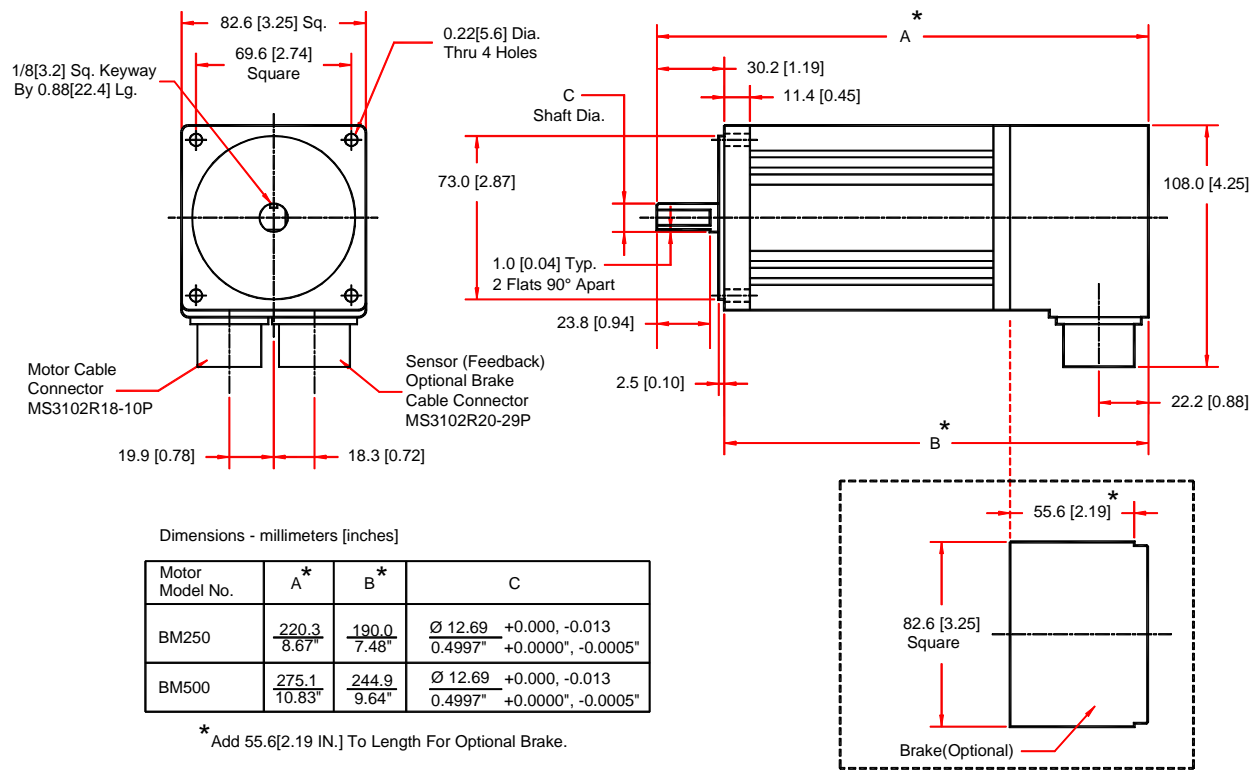

Figure 1-12: BM250, BM500 Model Dimensions

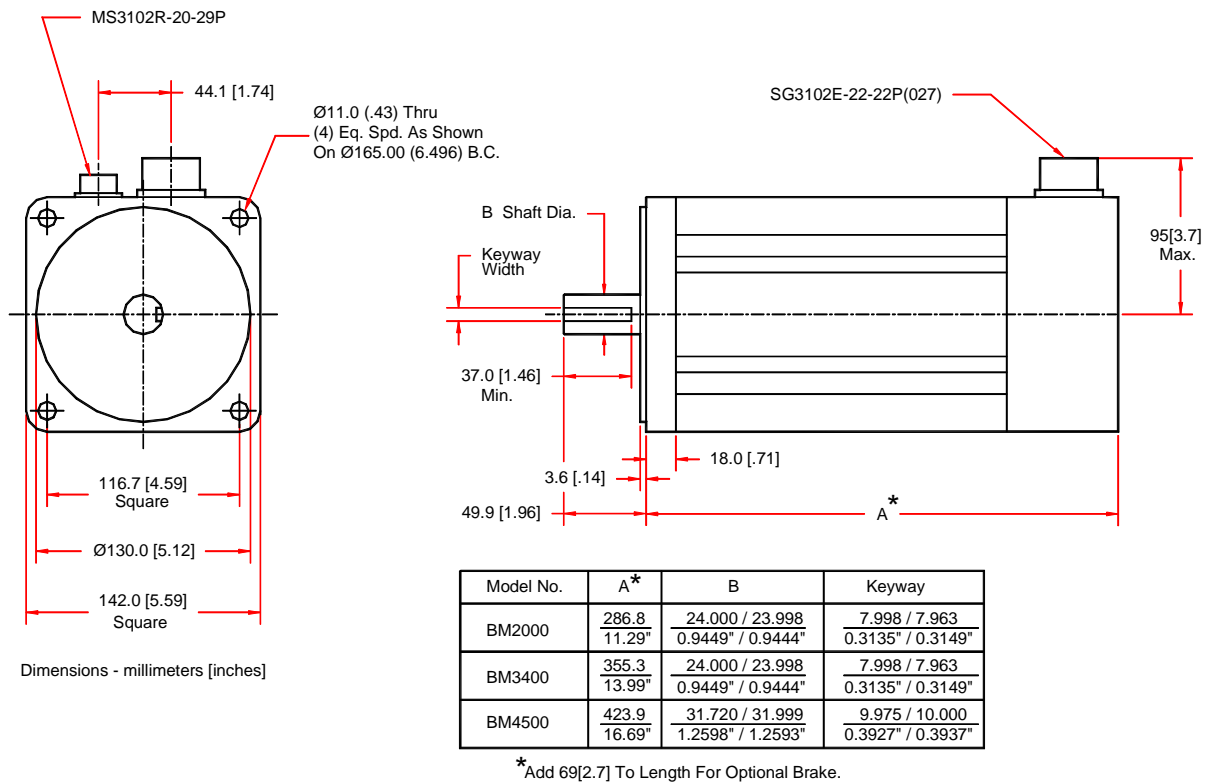

Figure 1-13: BM2000, BM3400, BM4500 Model Dimensions

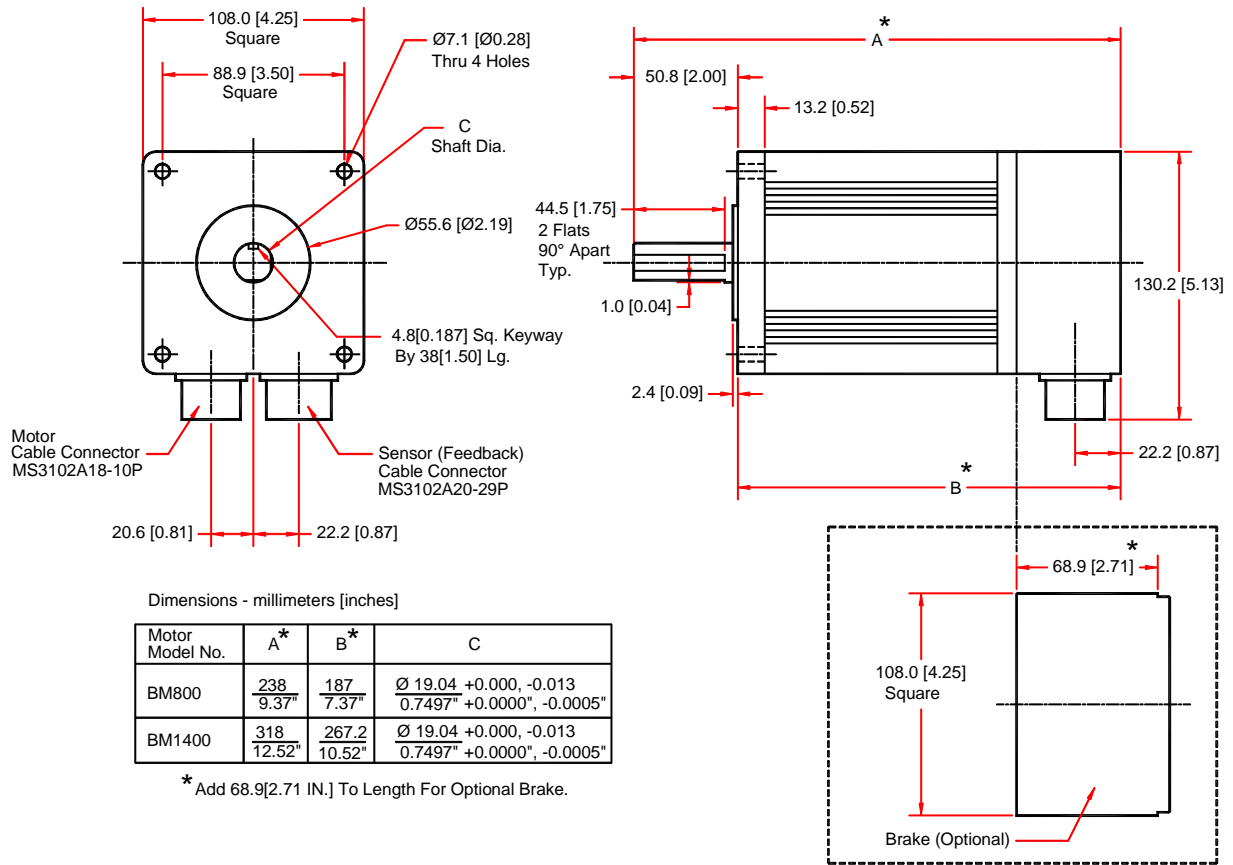

Figure 1-14: BM800, BM1400 Model Dimensions

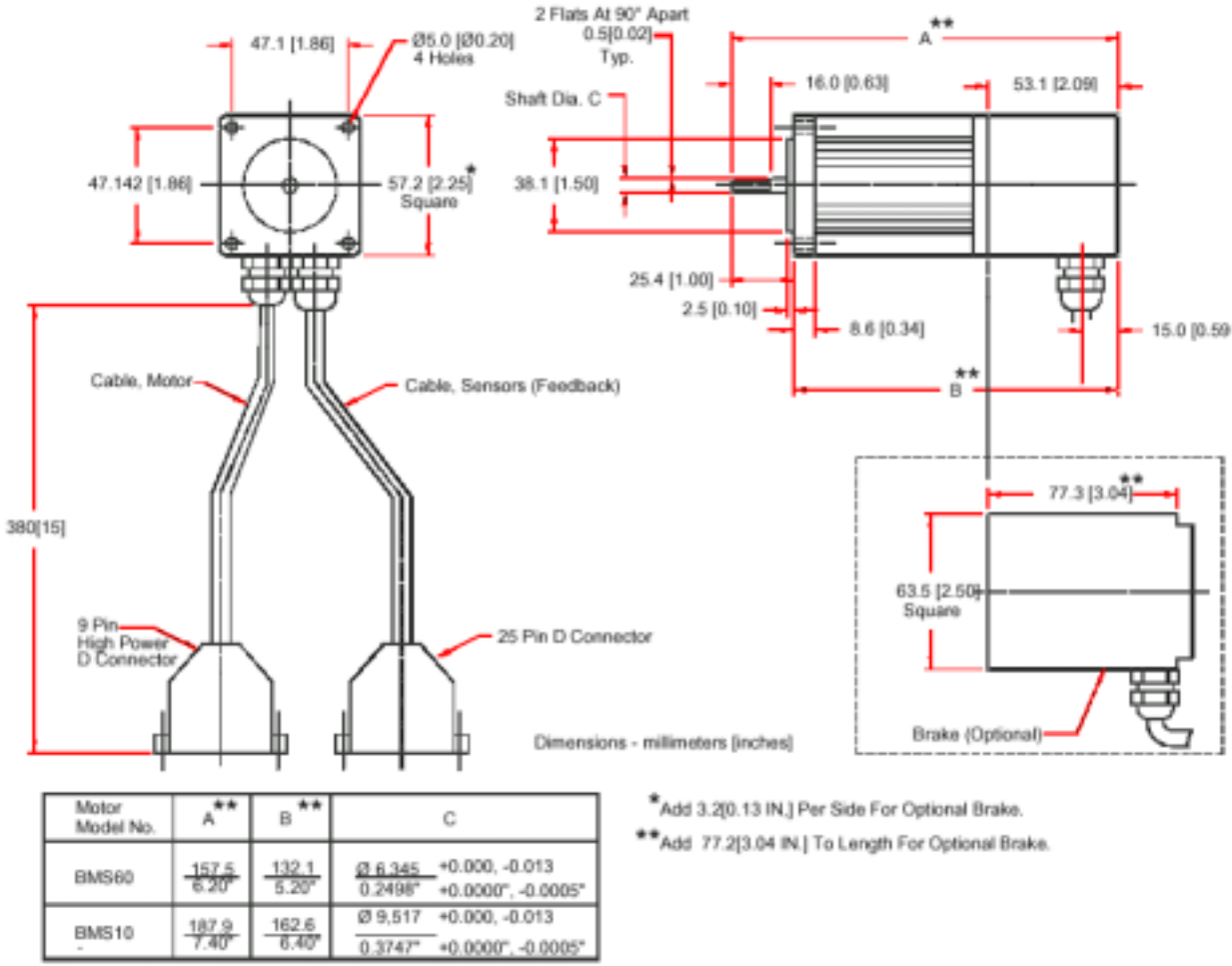

Figure 1-15: BMS60 and BMS100 Model Dimensions

Chapter 1 BM & BMS SERIES OVERVIEW

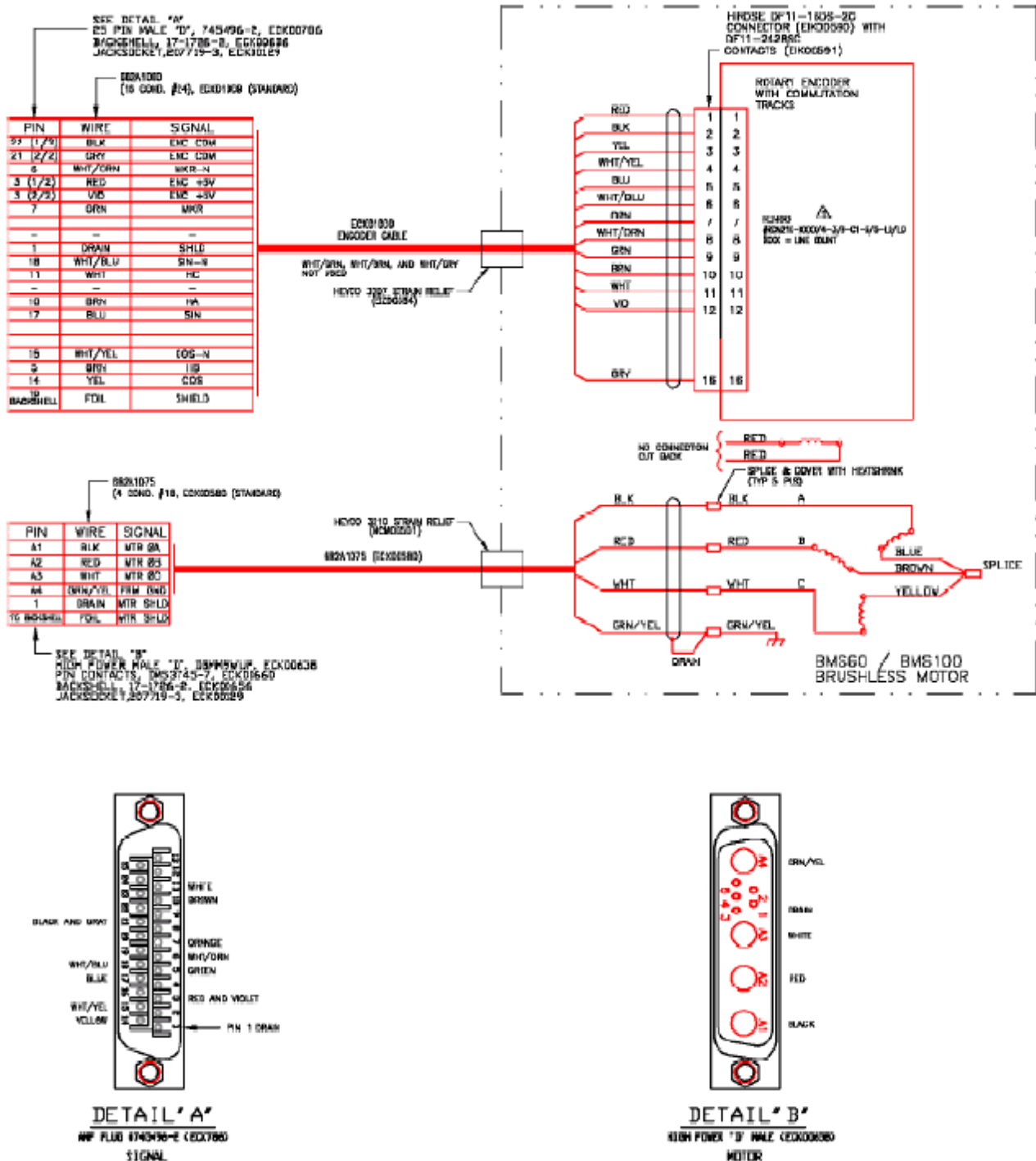

Figure 1-16: Pinouts for the BMS60 and BMS100 w/D-Shell Connectors

In this Chapter you will learn about:

Warranty
Return Policy
Technical Support
Assumptions
Shipment Inspection

2.1. Warranty

I²T warrants that all equipment they manufacture will be free from defects in materials and workman-ship for a period of one (1) year from the date of invoice. Within this warranty period, I²T shall, at its option, repair or replace – free of charge, any equipment covered by this warranty. This warranty does not cover any equipment damaged by improper installation, accident, alteration or misuse. In no event shall I²T be liable for incidental or consequential damages or for delay in performance of this warranty.

2.2. Return Policy

Any equipment returned as new must be in the original, unopened shipping carton and is subject to a 20% restocking fee. All equipment returned to I²T for repair or replacement, regardless of warranty status, must have return authorization. To receive return authorization, call the I²T technical assistance number with the following product information:

- Product Part Number
- Serial Number
- Description of Problem

I²T issues a Return Material Authorization (RMA) number. You must ship the product to I²T with shipping charges prepaid and the RMA clearly marked on the outside of the shipping container. Title and risk of loss or damage remains with the customer until shipment is received by I²T. All equipment returned for warranty repair must be in the original shipping container or additional handling charges apply. In special cases, I²T will provide emergency replacement of defective equipment. For special cases, the customer must provide a Purchase Order number in the amount of a product being shipped plus any applicable taxes and shipping charges. In the event that the defective equipment is not returned within seven (7) days, I²T bills the customer for the replacement equipment.

2.3. Technical Support

All I²T products are sold through authorized Schneider Electric high-tech distributors. The customer should attempt to resolve any problems through their local distributor before contacting I²T directly. Should your local distributor be unavailable or unable to solve a problem, contact I²T Technical Support at (412) 828-1200. Additional information and updates are available via our WEB site at <http://www.isquaredt.com>.

2.4. Assumptions

To effectively use the BM/BMS Series User's Guide to install, develop and maintain your setup, you should have a fundamental understanding of the following:

- Electronic concepts such as voltage, current, switches, etc.
- Motion control concepts
- Contents of this User's Guide.

2.5. Shipment Inspection

Check your BM or BMS Series package, upon receipt, for obvious damage that may have occurred during shipment. Report any damage to the shipping company immediately. I²T cannot be held responsible for damage incurred during shipment.

Retain the shipping container in case you need to return the motor for any reason. Any damage incurred due to improper packing is the responsibility of the shipper and will further delay the repair or replacement of your parts.